

FOR REVIEW
NOT TO BE USED FOR CONSTRUCTION

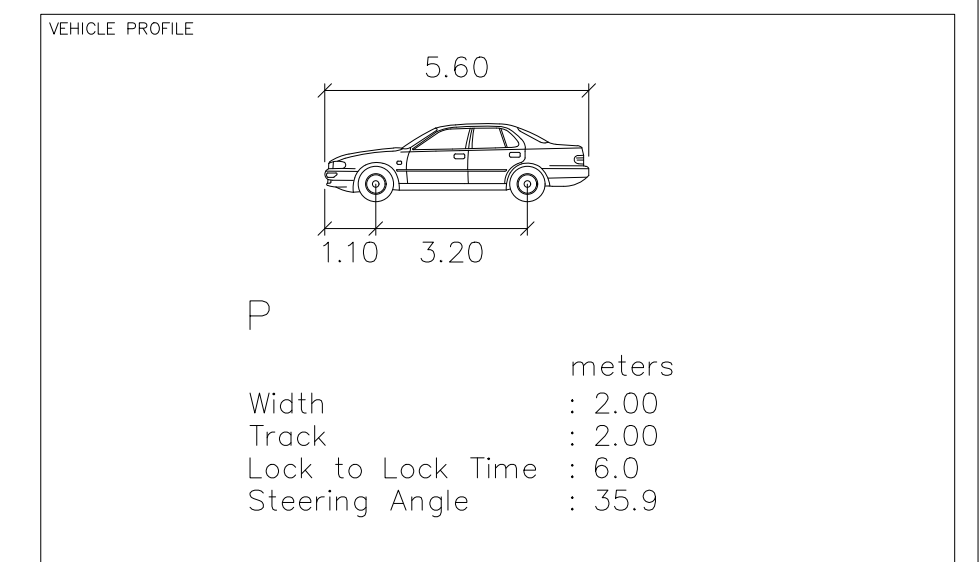
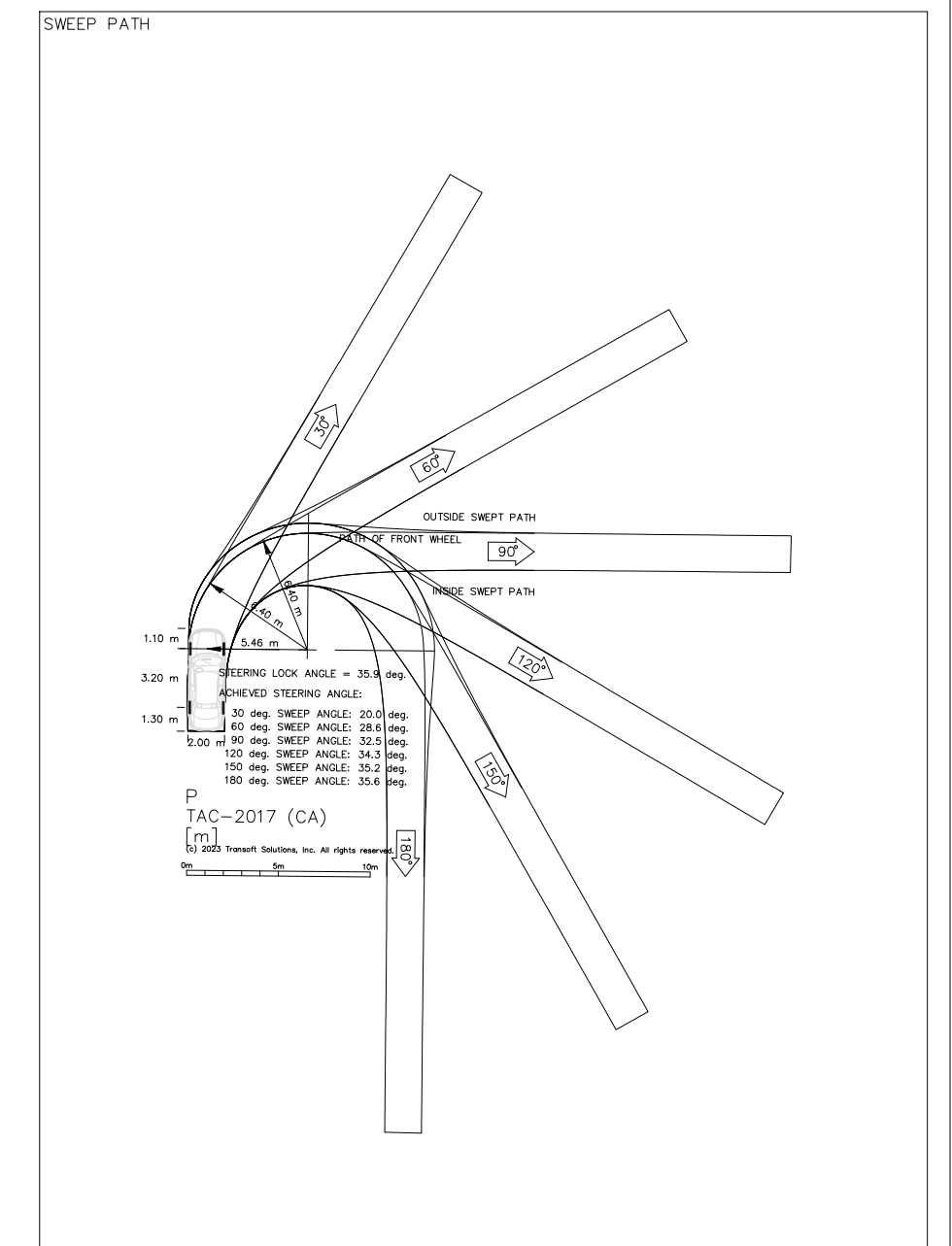
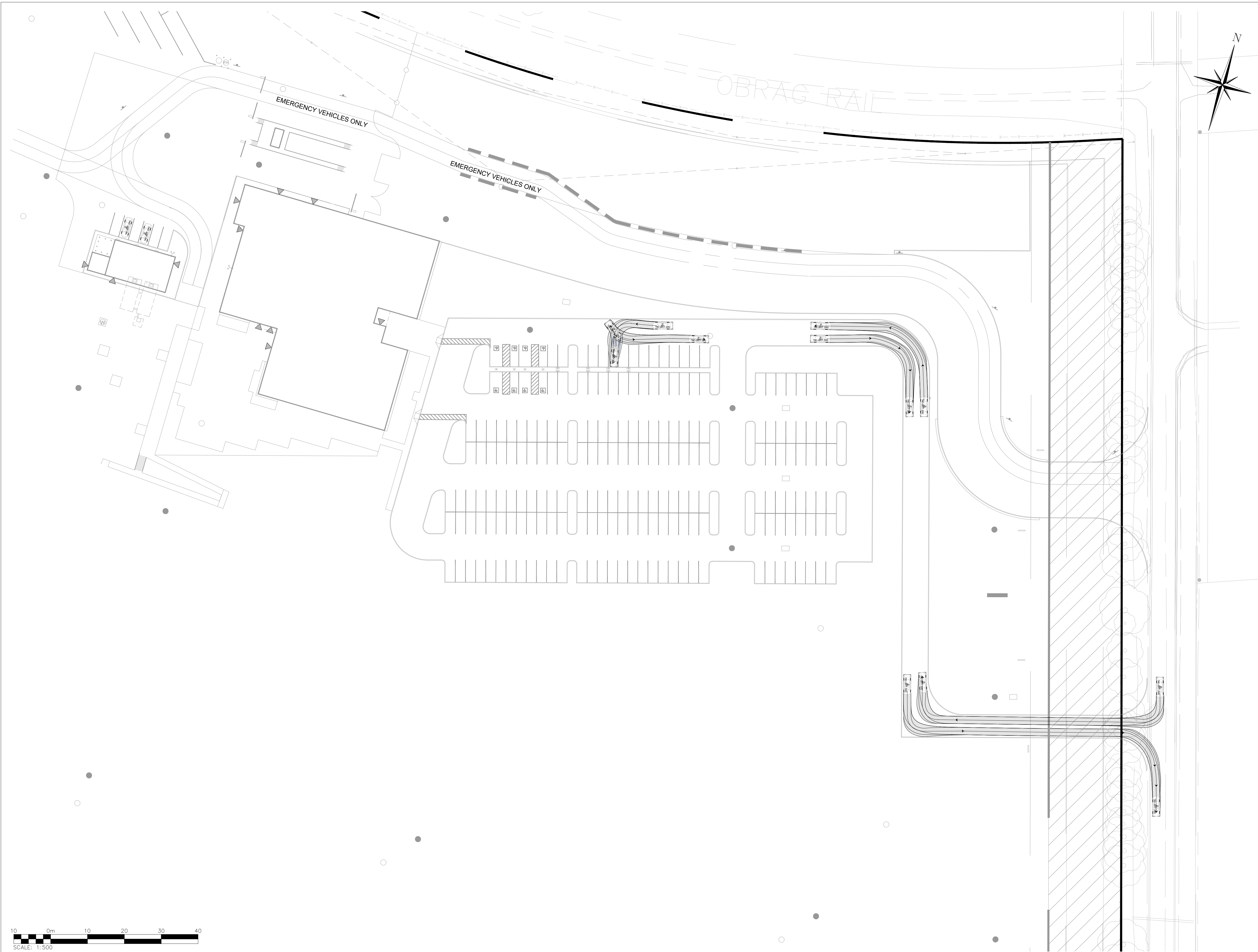
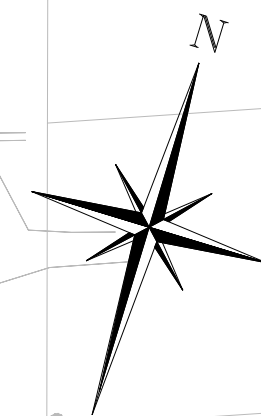

No.	ISSUE	DATE: MM/DD/YYYY
1	ISSUED FOR SUBMISSION	07/14/2023
2	ISSUED FOR REVIEW	11/16/2023

Project
RITCHIE BROS.
2ND LINE & DUFFERIN ROAD 109
TOWNSHIP OF AMARANTH
COUNTY OF DUFFERIN

Drawing
PASSENGER CAR
VEHICLE MANEUVERING ANALYSIS

2800 HIGH POINT DRIVE
SUITE 100
MILTON, ON, L9T 6P4
905-875-0026 T
905-875-4915 F
WWW.CROZIER.CA
INFO@CROZIER.CA

Drawn By	M.F.	Design By	Project	2375-6554
Check By	K.H.	Check By	Scale	1:500 Drawing T301



FOR REVIEW
NOT TO BE USED FOR CONSTRUCTION

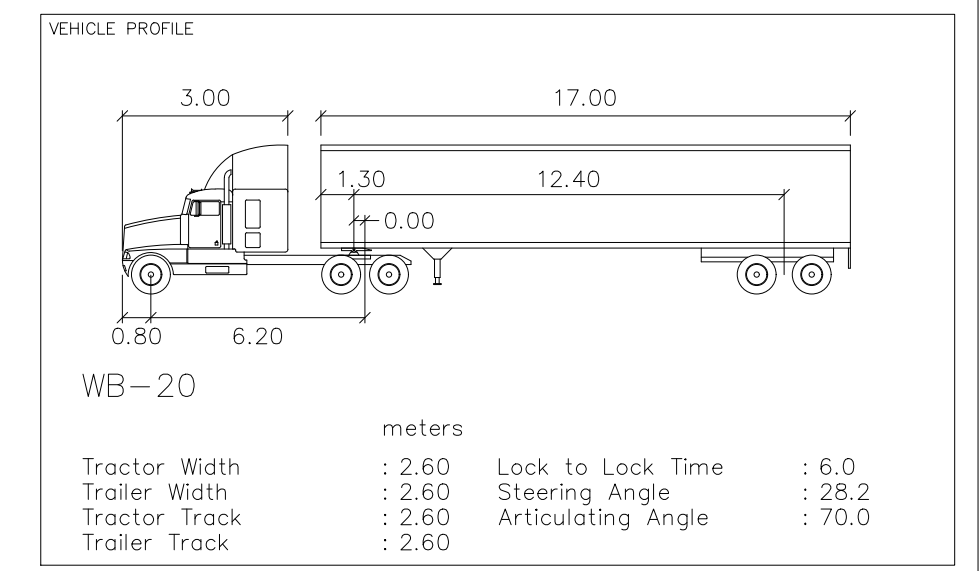
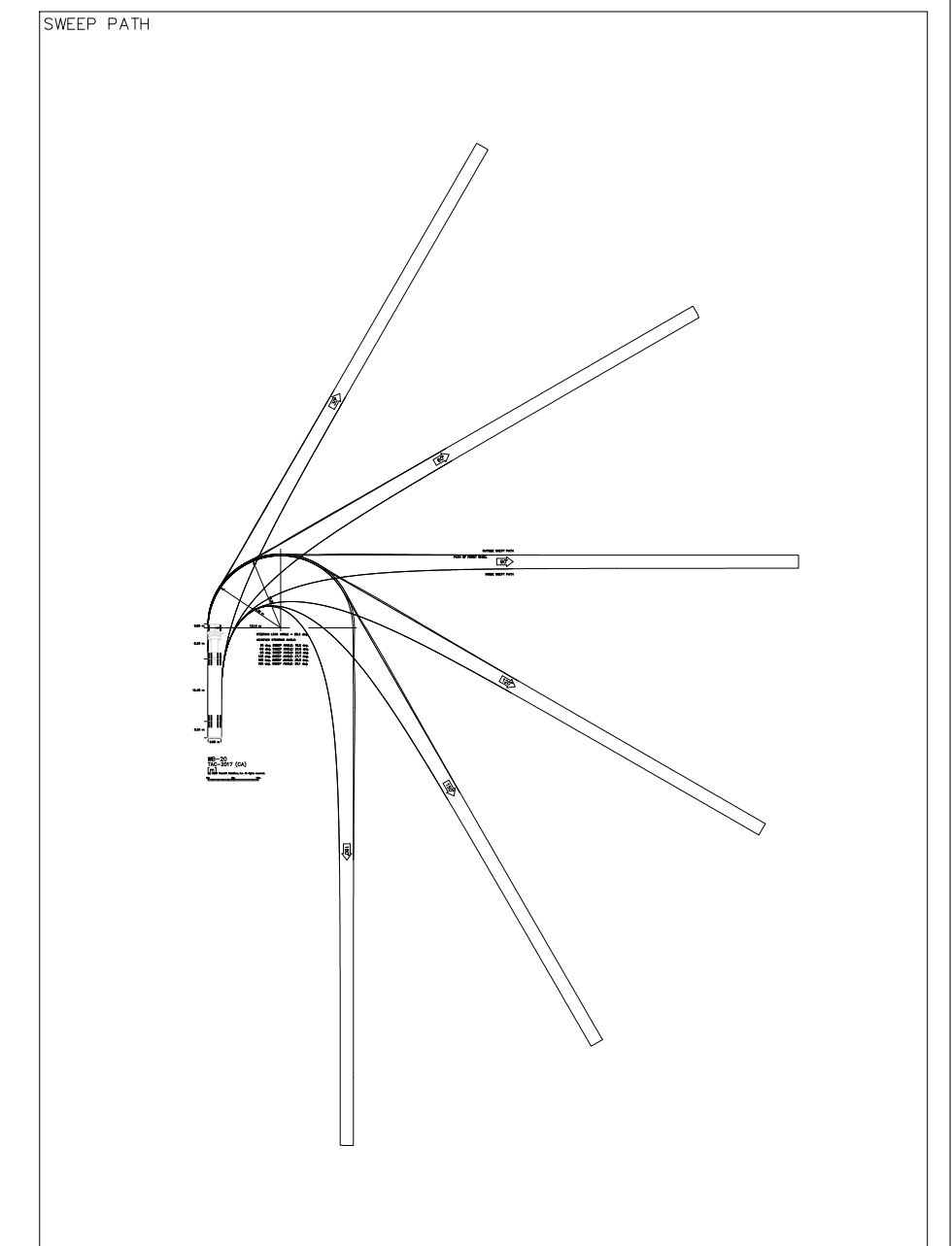
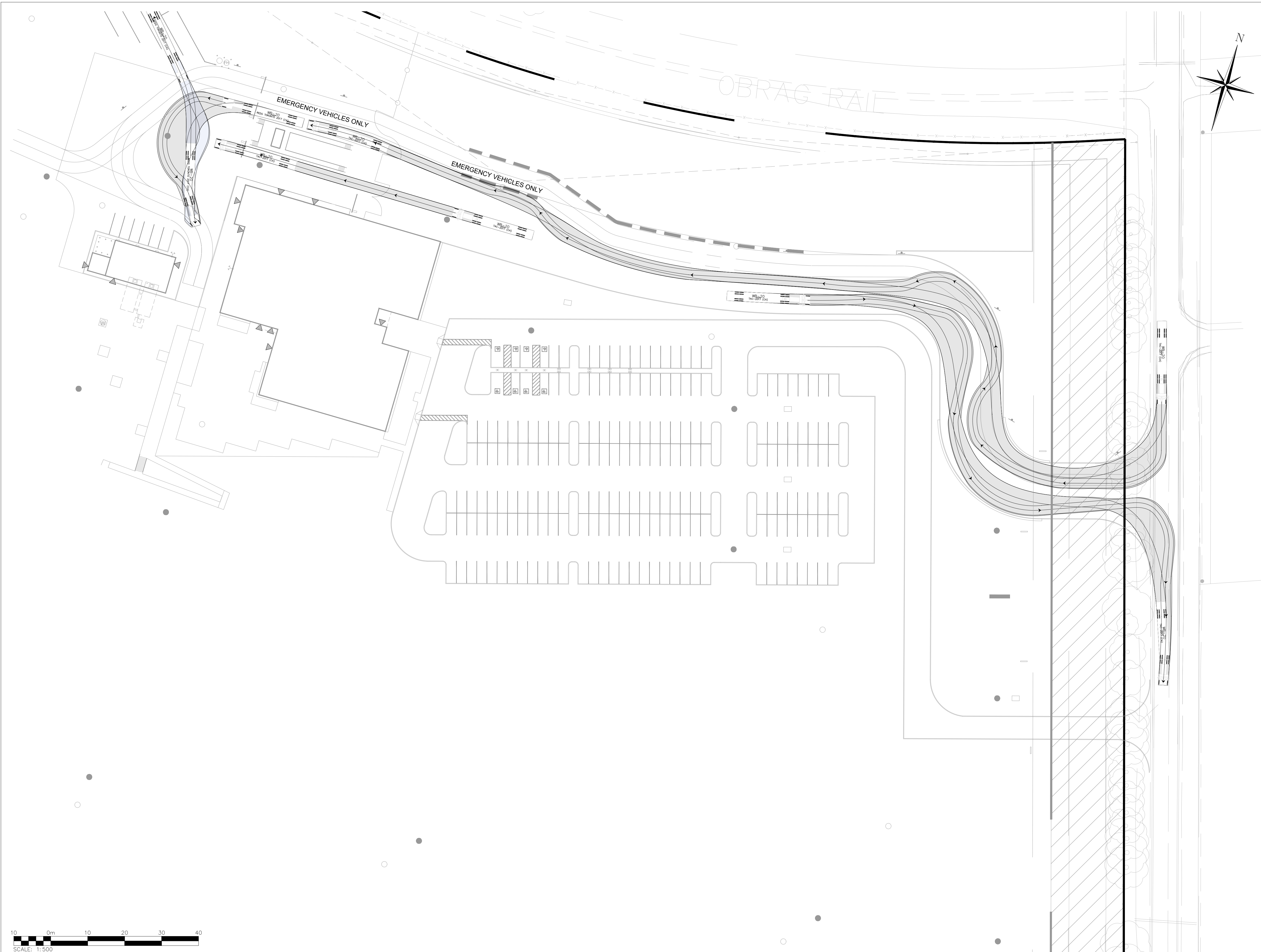
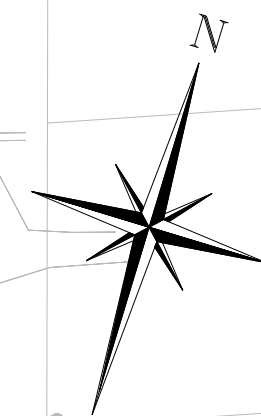

No.	ISSUE	DATE: MM/DD/YYYY
1	ISSUED FOR SUBMISSION	07/14/2023
2	ISSUED FOR REVIEW	11/16/2023

Project
RITCHIE BROS.
2ND LINE & DUFFERIN ROAD 109
TOWNSHIP OF AMARANTH
COUNTY OF DUFFERIN

Drawing
WB-20
VEHICLE MANEUVERING ANALYSIS

2800 HIGH POINT DRIVE
SUITE 100
MILTON, ON, L9T 6P4
905-875-0026 T
905-875-4915 F
WWW.CROZIER.CA
INFO@CROZIER.CA

Drawn By	M.F.	Design By	Project	2375-6554
Check By	K.H.	Check By	Scale	1:500
			Drawing	T302

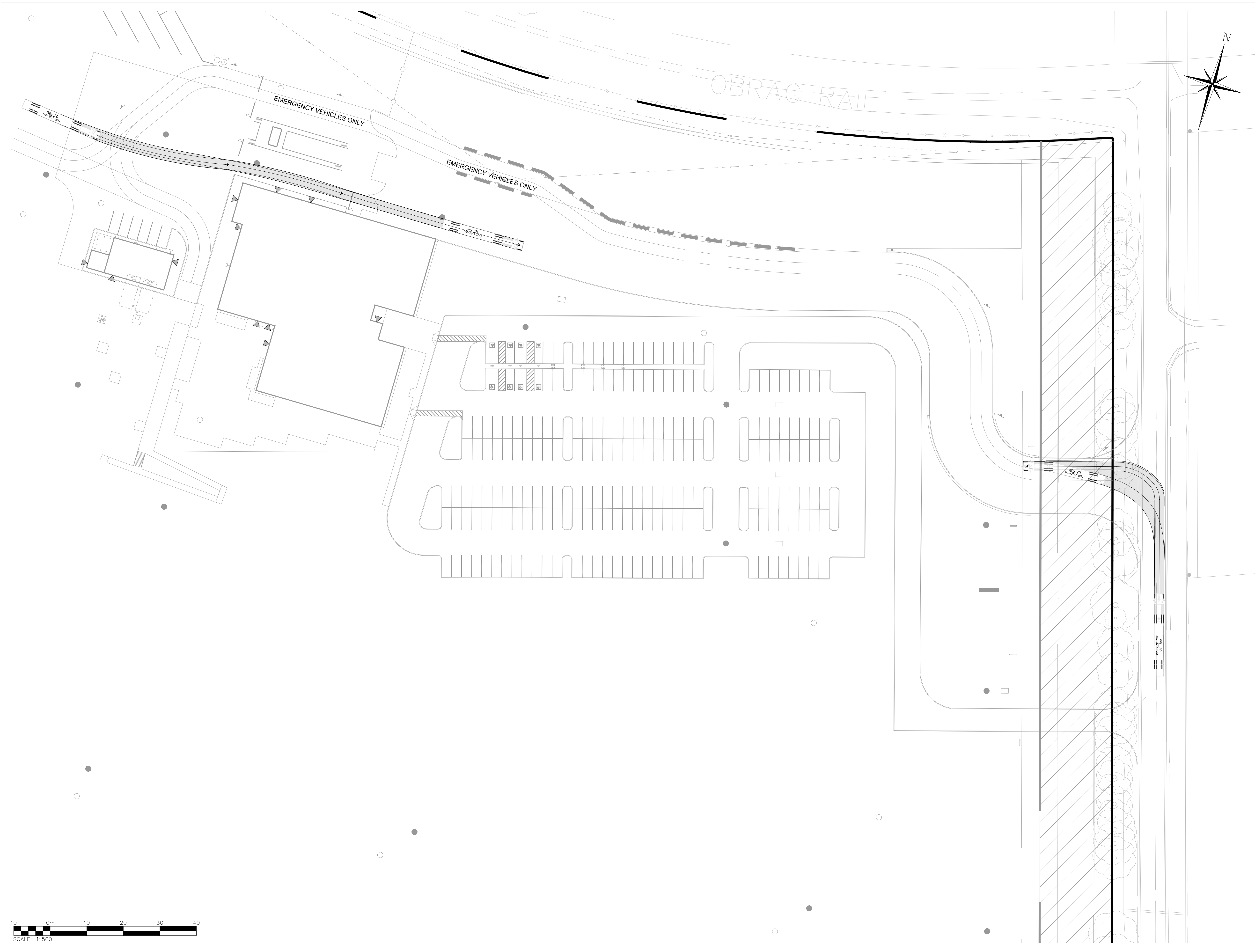

FOR REVIEW
NOT TO BE USED FOR CONSTRUCTION

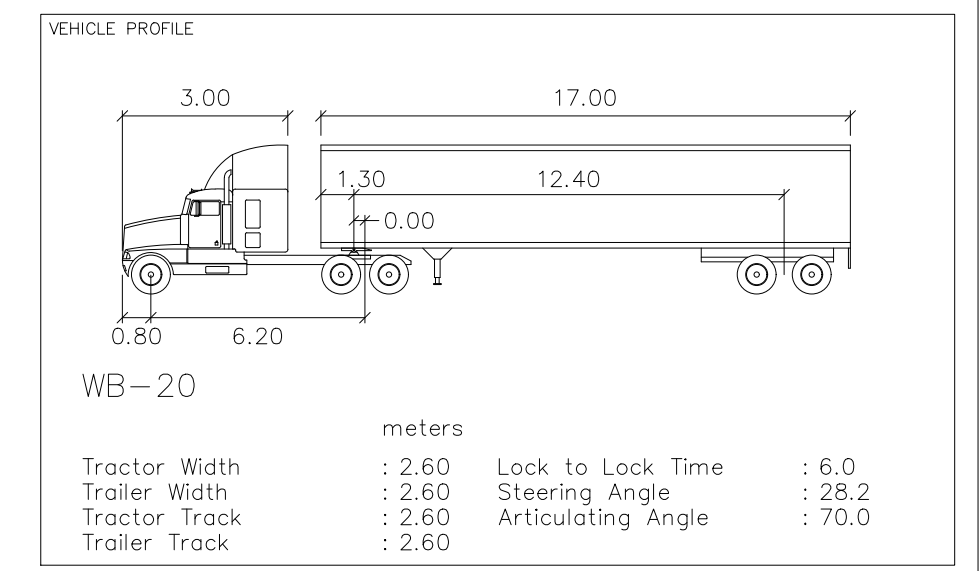
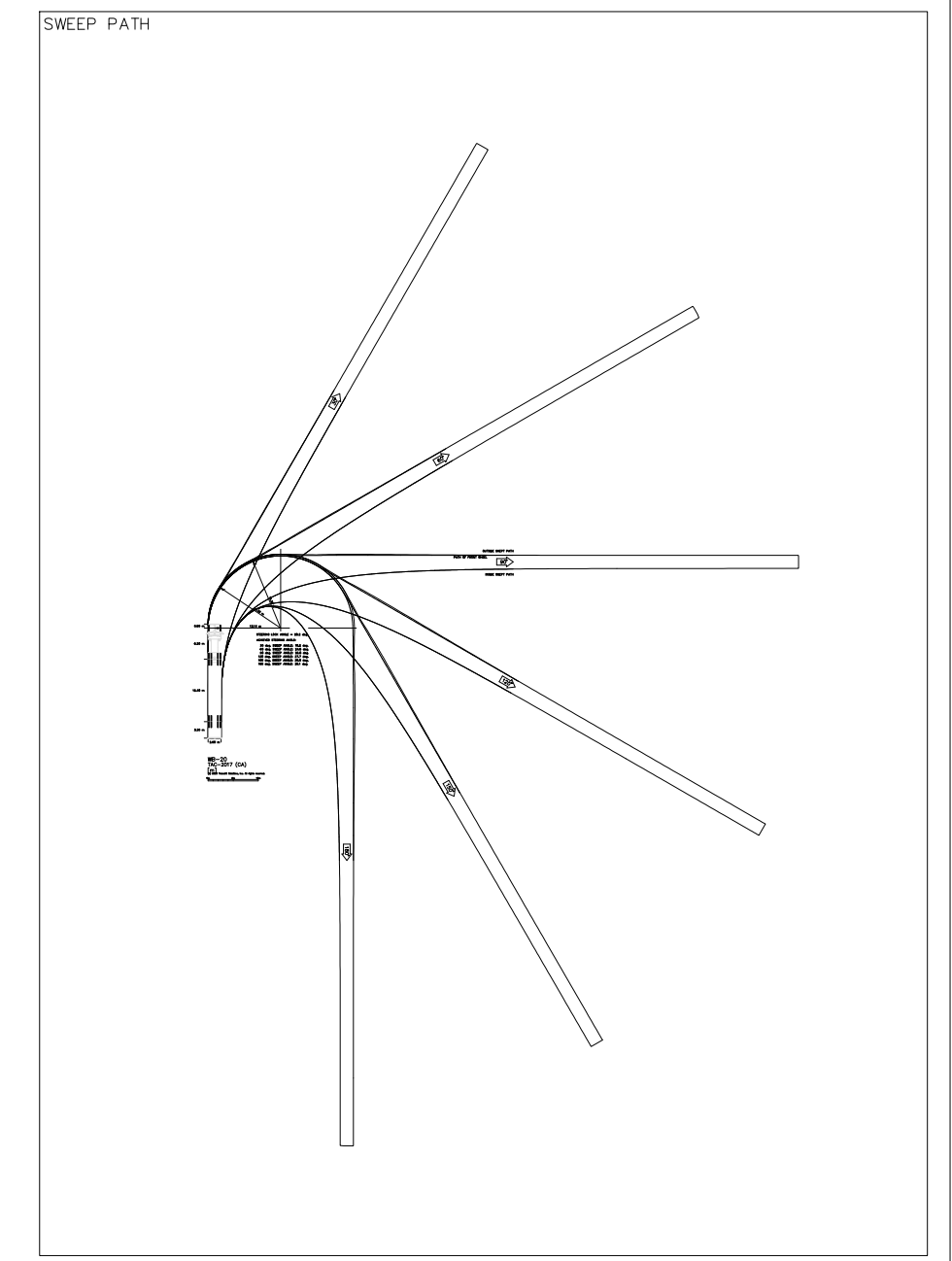

No.	ISSUE	DATE: MM/DD/YYYY
1	ISSUED FOR SUBMISSION	07/14/2023
2	ISSUED FOR REVIEW	11/16/2023

Project
RITCHIE BROS.
2ND LINE & DUFFERIN ROAD 109
TOWNSHIP OF AMARANTH
COUNTY OF DUFFERIN

Drawing
WB-20
VEHICLE MANEUVERING ANALYSIS

2800 HIGH POINT DRIVE
SUITE 100
MILTON, ON, L9T 6P4
905-875-0026 T
905-875-4915 F
WWW.CROZIER.CA
INFO@CROZIER.CA

Drawn By	M.F.	Design By	Project	2375-6554
Check By	K.H.	Check By	Scale	1:500
			Drawing	T303

